

# Catálogo Industrial

Industrial catalogue  
Catalogue industriel  
Industrielle Katalog



*filinox*

# La empresa



## LA EMPRESA

Desde 1965 somos especialistas en la transformación y manipulación del Acero Inoxidable, con el que desarrollamos productos para la industria y el hogar.

Este material, resistente a la corrosión y duradero, unido a nuestra experiencia, nos permite ofrecer productos de máxima calidad.

En este catálogo les presentamos una muestra de proyectos realizados para el sector industrial. Trabajamos en colaboración con nuestros clientes en el desarrollo de productos que aporten soluciones a sus necesidades. Servicio y profesionalidad son los valores fundamentales sobre los que basamos nuestra actividad diaria.

## NUESTRA LOGÍSTICA

Nuestra plataforma logística Loginox está dotada de los últimos avances tecnológicos, y nos permite disponer de una gran capacidad operativa y ofrecer la máxima calidad en el servicio.

## COMPROMISO DE CALIDAD

Todos nuestros productos se adaptan a los requerimientos de nuestros clientes. Nuestro proceso de fabricación está avalado por la certificación ISO 9001

## ACABADOS

Realizamos una amplia gama de acabados, como el industrial, decapado o electropulido. Todos los acabados se realizan en nuestras instalaciones, con equipos propios de última tecnología y siguiendo procesos respetuosos con el medio ambiente.

#### THE COMPANY

Filinox, S.A. was founded in 1965, specializing itself in transformation and manipulation of Stainless Steel and develops solutions for industry and home equipment.

We use a noble material, resistant to corrosion and of long duration which allows us to offer high quality products.

In this catalogue, we present some projects examples carried out for the industrial sector. We work in collaboration with our clients to make products that bring solutions to their needs. Service and Professionalism are the core values on which our daily activity is based.

#### LOGISTICS

Our logistics platform Loginox is provided with the last technological advances which allows us to dispose of an important operative capacity and to offer a guaranteed highest quality service.

#### QUALITY COMMITMENT

All our products meet our clients' requirements. Our production process is ISO 9001 certified.

#### FINISHED

We propose a wide range of finishing: industrial, pickling or electro-polishing.

All the finishings are carried out within our facilities, with our last technology equipments and through environment friendly processes.

#### L'ENTREPRISE

*Depuis 1965, nous sommes spécialisés dans la transformation et la manipulation de l'Acier Inoxydable et développons des produits pour l'industrie et les ménages.*

*Ce matériau, résistant à la corrosion et de longue durabilité, auquel s'ajoute notre expérience, nous permet d'offrir des produits de qualité maximale.*

*Dans ce catalogue, nous vous présentons des exemples de projets réalisés pour le secteur industriel. Nous travaillons en collaboration avec nos clients sur le développement des produits, apportant ainsi des solutions à leurs besoins. Le Service et le Professionalisme sont les valeurs fondamentales sur lesquelles nous basons notre activité quotidienne.*

#### NOTRE LOGISTIQUE

*Notre plateforme logistique Loginox est dotée des dernières avancées technologiques, ce qui nous permet de disposer d'une grande capacité opérationnelle et d'offrir un service de qualité maximale.*

#### NOTRE ENGAGEMENT QUALITÉ

*Tous nos produits s'adaptent aux exigences de nos clients. Notre processus de fabrication est certifié ISO 9001.*

#### FINITIONS

*Nous proposons une large gamme de finitions telles que: industrielle, décapage et électropolissage. Toutes les finitions sont réalisées dans nos installations, avec des équipements de dernière technologie et selon des procédés respectueux de l'environnement.*

#### DIE FIRMA

Seit 1965 sind wir in der Verarbeitung und Handhabung von Edelstahl spezialisiert. Wir entwickeln Produkte für die Industrie und Haushaltsgeräte.

Dieses korrosionsbeständige und langlebige Material, gepaart mit unserer Erfahrung, ermöglicht uns, hochwertige Produkte anzubieten.

In diesem Katalog präsentieren wir Ihnen eine Auswahl von Projekten, die für die Industrie durchgeführt wurden. Wir arbeiten gemeinsam mit unseren Kunden an der Produktentwicklung, um Lösungen für Ihre Bedürfnisse zu erfinden. Service und Professionalität sind die Grundwerte, auf denen wir unsere täglichen Aktivitäten gründen.

#### UNSERE LOGISTIK

Loginox, unsere Logistik-Plattform, ist mit den neuesten technologischen Fortschritten ausgestattet, und das ermöglicht uns, große operative Kapazitäten und einen Dienst mit höchster Qualität anzubieten.

#### QUALITÄTSVERPFLICHTUNG

Alle unsere Produkte erfüllen die Anforderungen unserer Kunden. Unsere Produktion ist ISO 9001 zertifiziert.

#### OBERFLÄCHEN

Wir führen eine breite Palette von Oberflächen, wie zB Industrie, Beizen oder Elektro-Radierung. Alle Ausführungen werden in unserer Einrichtung mit unseren eigenen Geräten der neuesten Technologie durch umweltfreundlichen Prozess hergestellt.

# Industria Alimentaria



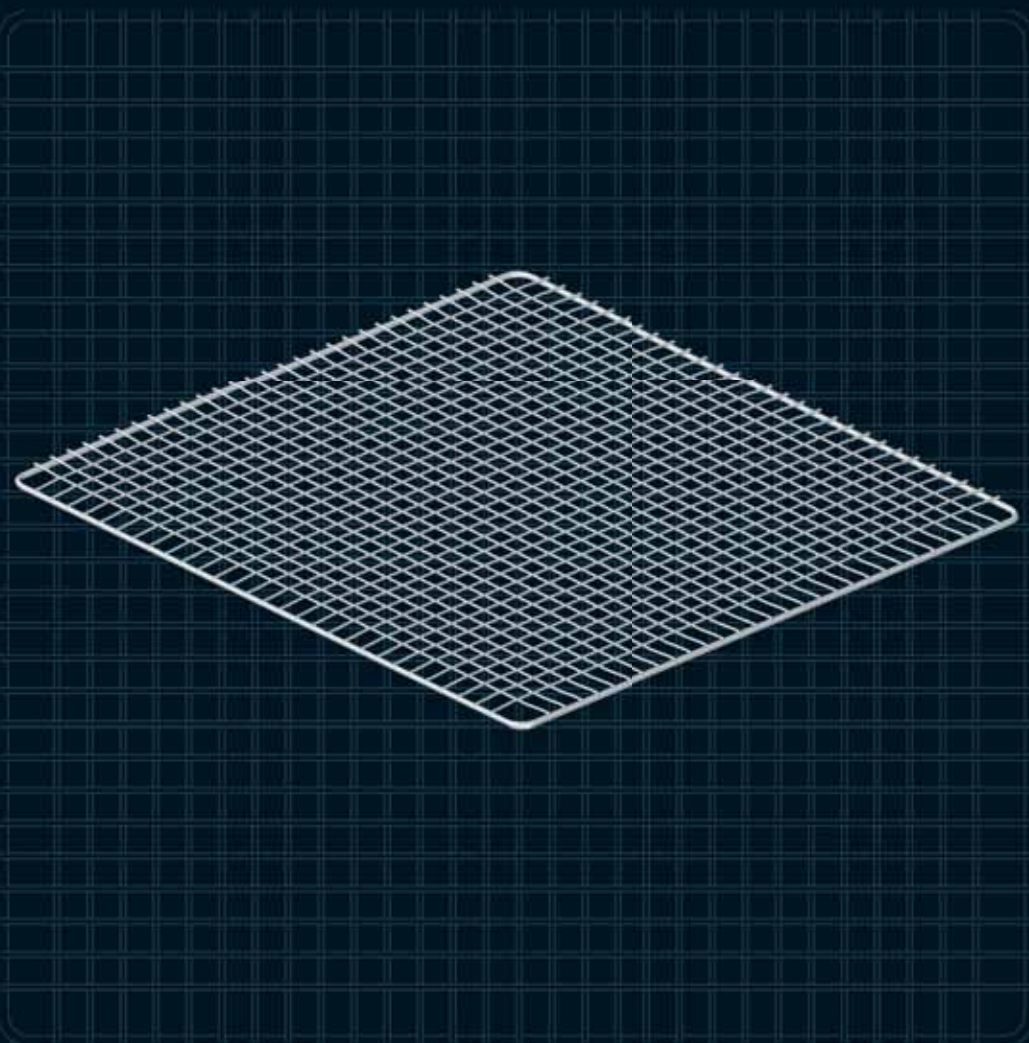

 **Industria alimentaria**

Siguiendo las estrictas normativas de higiene, calidad y resistencia fabricamos productos para diferentes sectores de la industria alimentaria. Desarrollamos artículos para la industria cárnica, avícola, ganadera, apícola...

 **Food industry**

According to the strict regulations concerning hygiene, quality and resistance, we make products for different food industry sectors. We develop articles for meat industry, poultry industry, cattle industry, beekeeping...

 **Industrie agroalimentaire**

Selon les normes strictes d'hygiène, de qualité et de résistance, nous fabriquons des produits pour différents secteurs de l'industrie agroalimentaire. Nous développons des articles pour les industries de la viande et de la volaille, l'élevage, l'apiculture...

 **Lebensmittelindustrie**

Unter Beachtung der strengen Hygiene-, Qualitäts- und Beständigkeitsregeln stellen wir Produkte für unterschiedliche Bereiche der Lebensmittelindustrie her. Wir entwickeln Artikel für die Fleischindustrie, die Geflügelindustrie, das Viehzucht, das Bienenzucht...

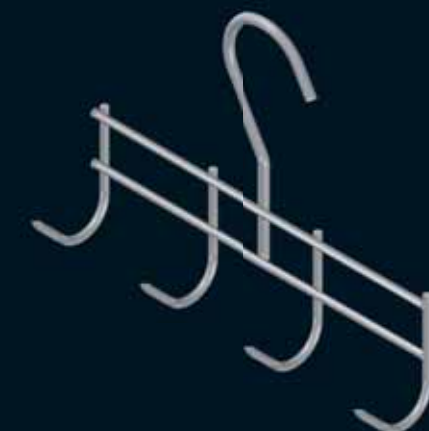
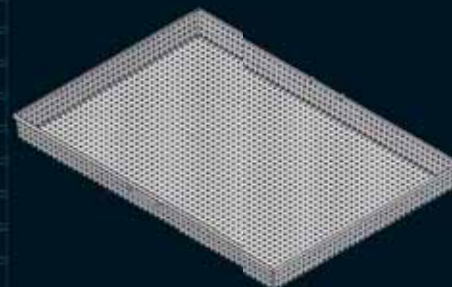
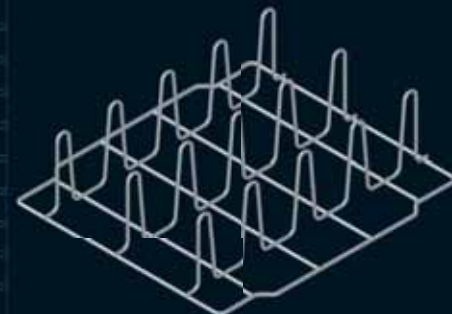

# Industria Conservera



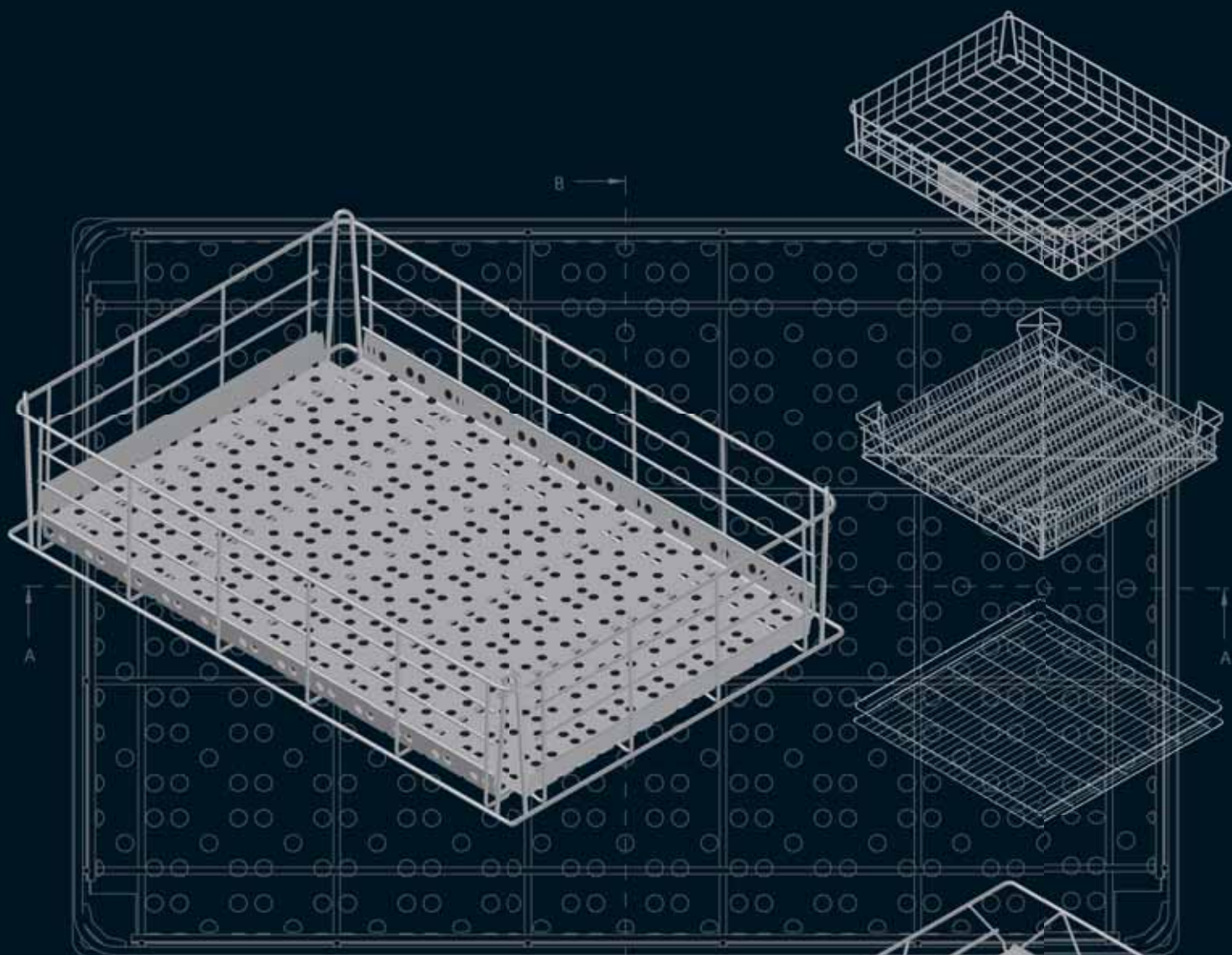

 **Industria Conservera**

Higiene y durabilidad son las características principales del acero inoxidable. Nosotros lo transformamos y adaptamos para elaborar componentes para procesos de cocción, salazón, ahumado, etc., tan necesarios en la industria conservera

 **Industrie conserverie**

Hygiène et durabilité sont les caractéristiques principales de l'acier inoxydable. Nous le transformons pour élaborer des pièces adaptées aux procédés de cuisson, de salaison, de fumage, etc., tant nécessaires à l'industrie de la conserverie.

 **Canning industry**

Hygiene and Sustainability are stainless steel principal characteristics. We transform and adapt it to elaborate components for boiling, salting, smoking, etc. so necessary processes in the canning industry.

 **Konservenindustrie**

Hygiene und Nachhaltigkeit sind die wichtigsten Eigenschaften von Edelstahl. Wir verwandeln und passen es an um Komponenten für das Kochen, das Salzen, das Räuchern, usw... herzustellen, so notwendig in der Konservenindustrie.

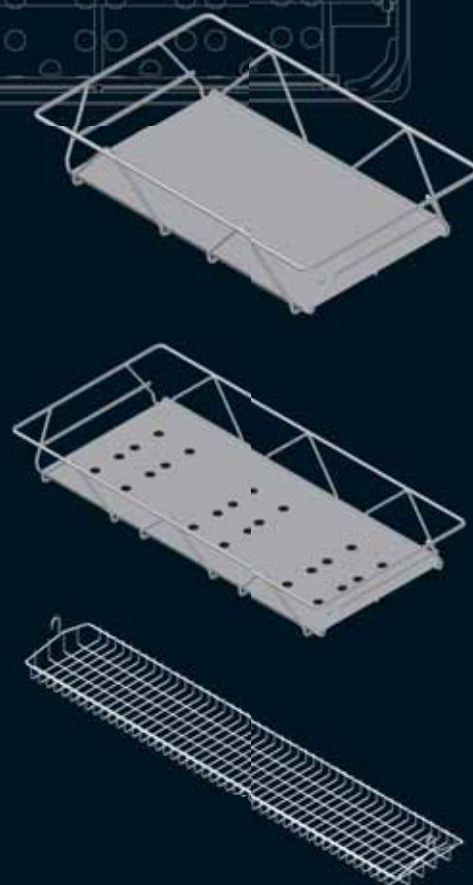

# Hostelería





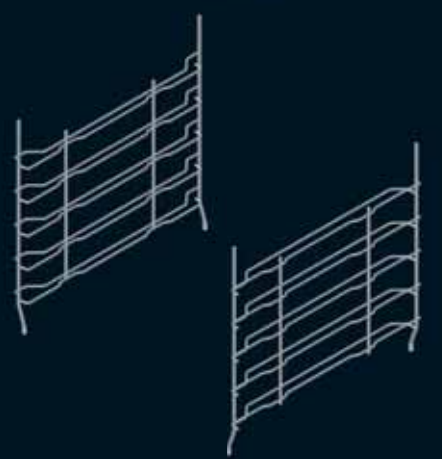
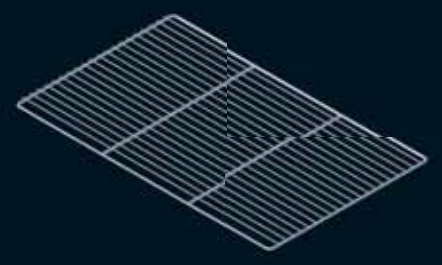
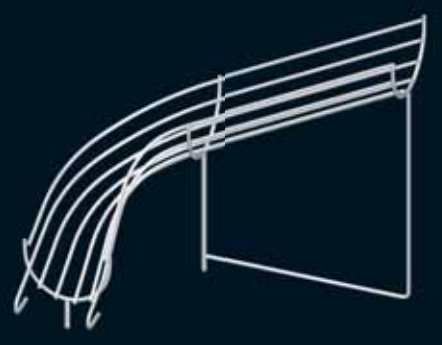



 **Hostelería**

Filinox desarrolla y fabrica una amplia gama de productos destinados al sector de la hostelería. Artículos destinados a distribuidores y fabricantes de maquinaria para el sector de la hostelería como cestas para freidoras, cestas para cocederas de pasta, emparrillados de cafeteras, parrillas para barbacoas... parrillas gastronorm, guías para bandejas de hornos...

 **Hôtellerie-restauration**

Filinox développe et fabrique une large gamme de produits destinés aux secteurs de l'hôtellerie et de la restauration. Des articles destinés aux distributeurs et aux fabricants de machines pour le secteur de la restauration tels que des paniers à frire, des paniers à pâtes, des grilles pour machines à café, des grilles pour barbecues... des grilles gastronomiques, des glissières pour plaques de four...

 **Catering sector**

Filinox develops and makes a wide range of products intended for the Catering sector. Articles intended for distributors and machinery manufacturers for the Catering sector like frying baskets, pastas baskets, coffee machine grills, barbecue grills... gastronorm grills, oven tray slides...

 **Gaststättengewerbe**

Filinox entwickelt und stellt ein breites Produktspektrum für den Gaststättengewerbe her. Artikel für Händler und Maschinenhersteller für die Gastronomie wie Fritierkorb, Pastaskorb, Tassenrahmen, Rostgrills... Gastronom Grill, Führungsleisten für Ofen...

# Colectividades



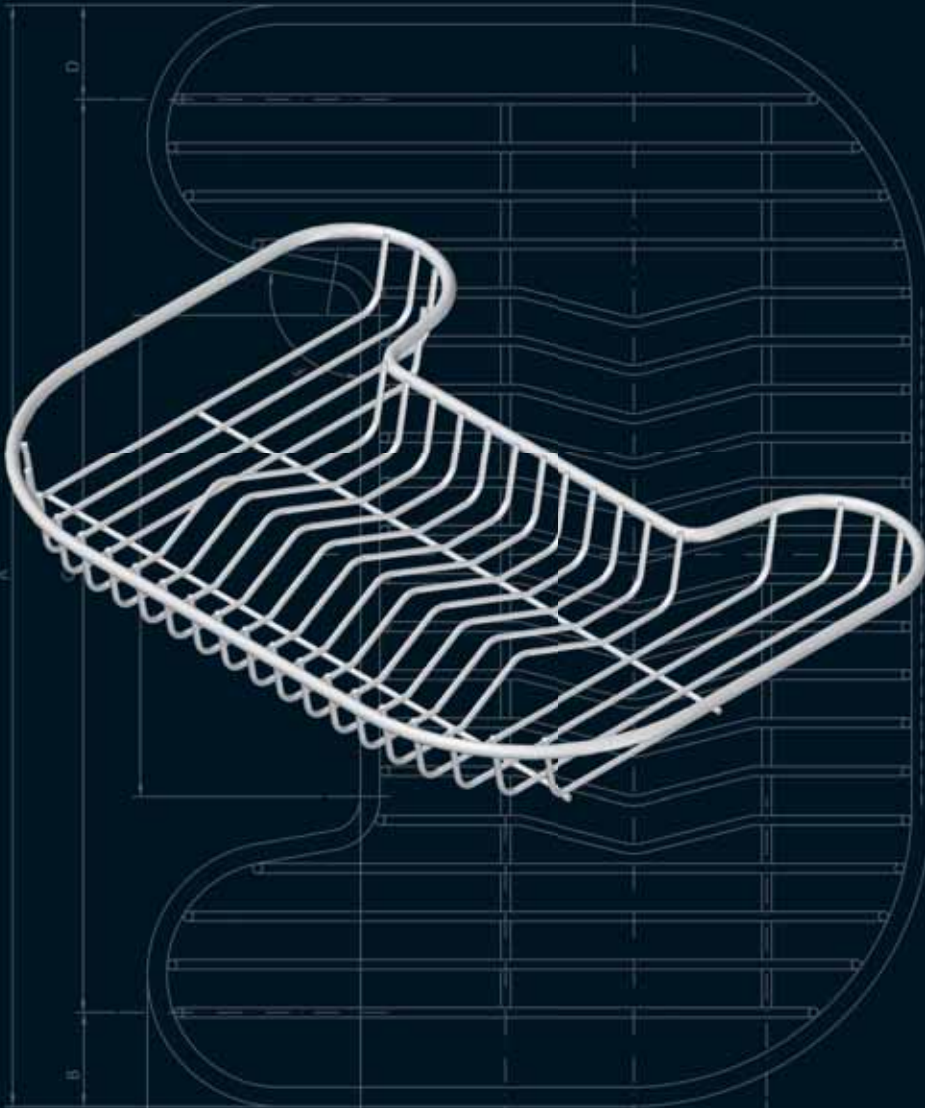

 **Colectividades**

Disponemos de una línea dedicada a las colectividades con más de 150 productos dedicados al ámbito industrial. Fabricamos cualquier producto que nuestros clientes necesiten, como: escurrer platos, escurrer vasos, cestas fregadero, complementos para sanitarios,...

 **Collectivities**

We have a line dedicated to collectivities with more than 150 products dedicated to industrial use. We make every products according to our clients' needs, like plate rack, glass rack, sink baskets, sanitary accessories,...

 **Collectivités**

Nous disposons d'une ligne dédiée aux collectivités avec plus de 150 produits destinés au secteur industriel. Nous fabriquons tous les produits dont nos clients ont besoin tels que des égouttoirs à assiettes, des égouttoirs à verres, des paniers pour éviers, accessoires pour le secteur sanitaire,...

 **Gemeinden**

Wir haben eine Produktlinie für die Gemeinden mit mehr als 150 Produkte. Wir stellen etliche Produkte nach Bedarf unserer Kunden, wie z. B. Tellerkorb, Gläser-rack, Waschbeckenkorbe, Sanitäränkomponenten, her...

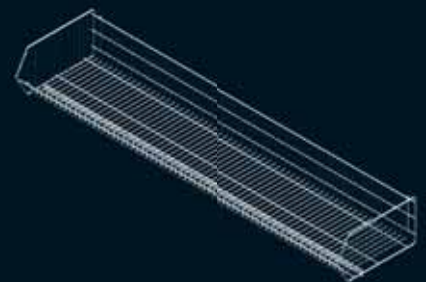
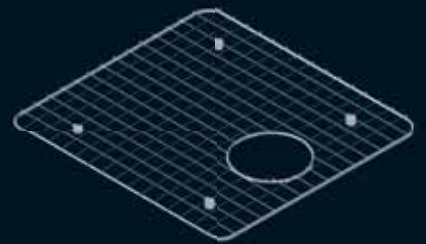
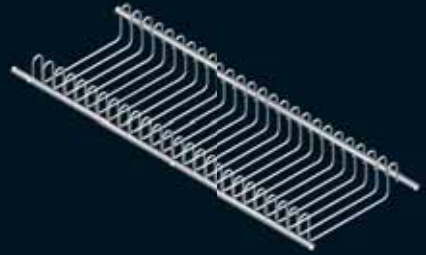
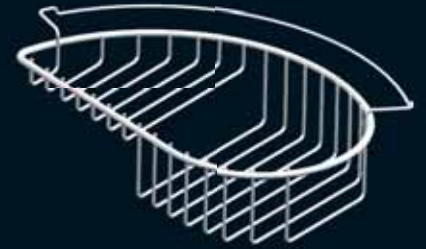
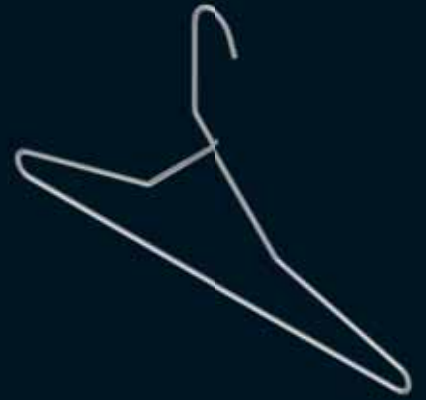

# Laboratorio y Hospitalario



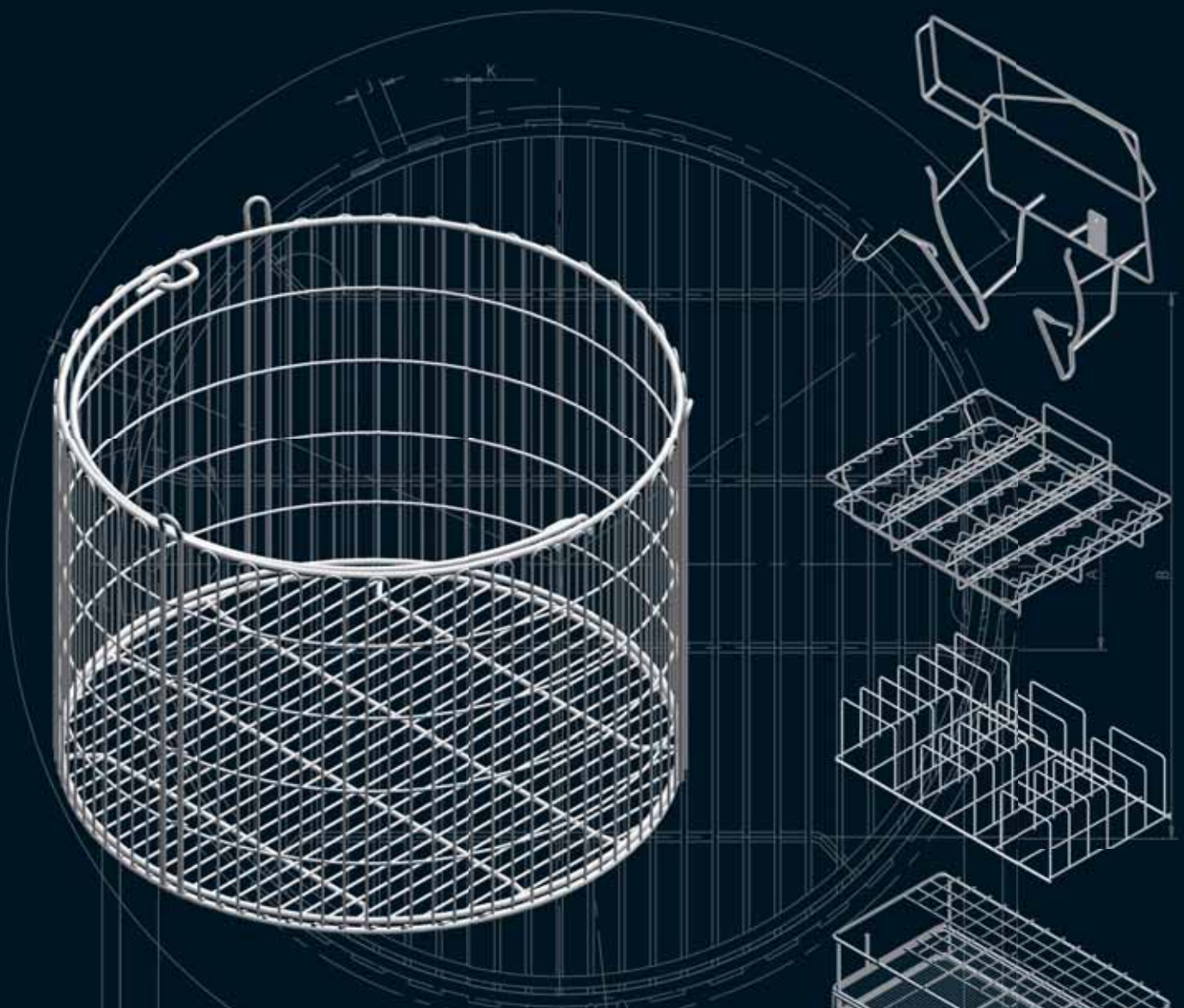

 **Hospitalario y laboratorio**

Utilizamos el acero inoxidable para ofrecer productos que se adaptan y siguen las estrictas normativas de higiene. Productos aptos para la esterilización, con acabados perfectos gracias a la utilización de la técnica del electropulido.

Fabricamos todo tipo de artículos destinados al ámbito hospitalario y laboratorio: soportes lavacañas, cestas de esterilización, cestas y guías para autoclaves...

 **Hospital and laboratory sector**

We use stainless steel to offer products that adapt and follow the strict regulations of hygiene. Suitable products for the sterilization, with a perfectly finished thanks to the use of the electro-polishing technology.

We make all kinds of articles intended for the Hospital and laboratory sector: supports for urinal pot washing, sterilization baskets, baskets and autoclaves slides...

 **Hôpitaux et laboratoires**

Nous utilisons l'acier inoxydable pour offrir des produits qui s'adaptent et répondent aux normes strictes d'hygiène. Nos produits sont appropriés à la stérilisation, avec une finition parfaite grâce à l'utilisation de la technique de l'électropolissage.

Nous fabriquons toutes sortes de produits pour hôpitaux et laboratoires : supports pour lave-bassins, paniers pour stérilisation, paniers et glissières pour autoclaves...

 **Krankenhaus- und laborgeräte**

Wir verwenden Edelstahl um Produkten, die die strengen Hygieneregeln beachten zu bieten. Produkte für die Sterilisation mit einem perfekten Finish durch der Elektro-Radierungstechnik.

Wir herstellen alle Arten von Produkten für den Krankenhaus- und Laborgeräte, Träger für Bettgeschüsselwäscher, Sterilisationskörbe, Körbe und Führungsleisten für Autoklaven...

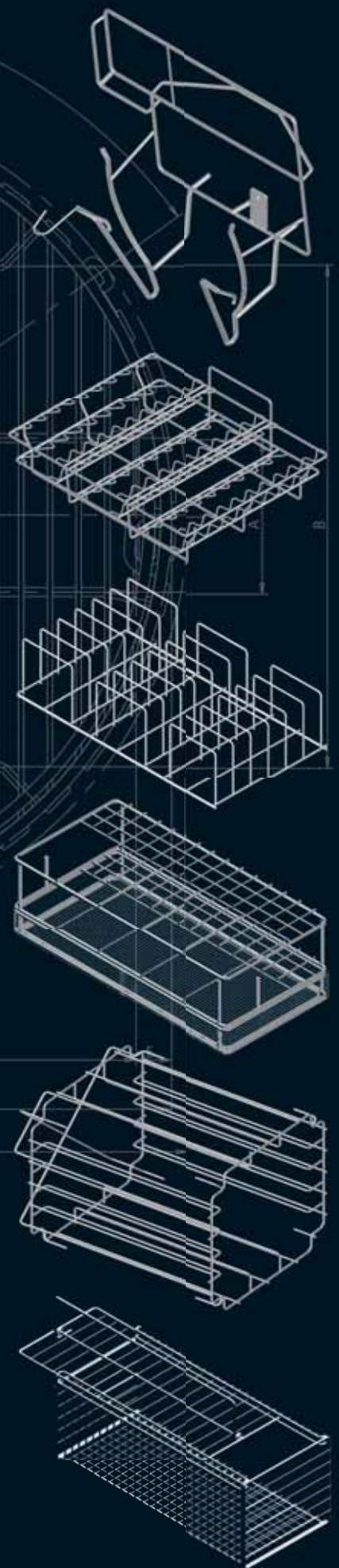

# Otros ejemplos de productos...

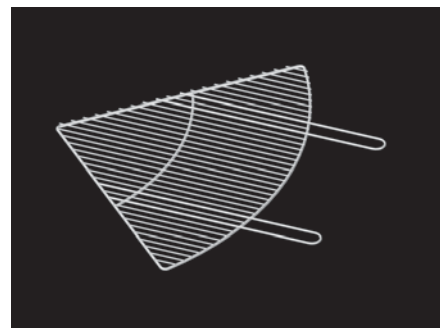
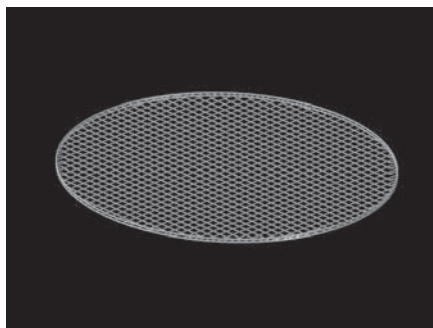
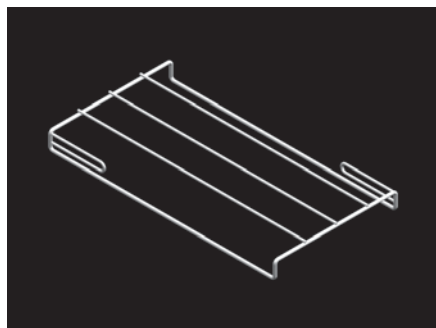
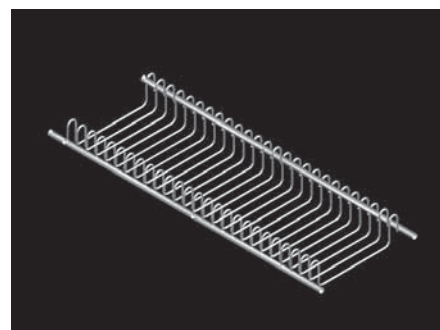
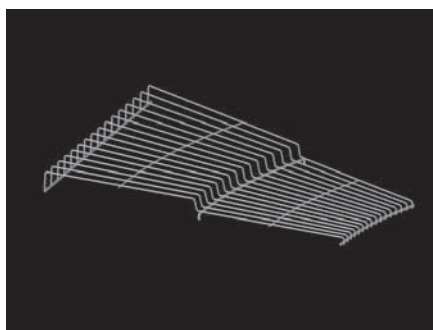
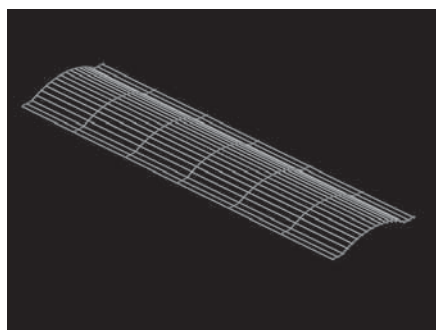
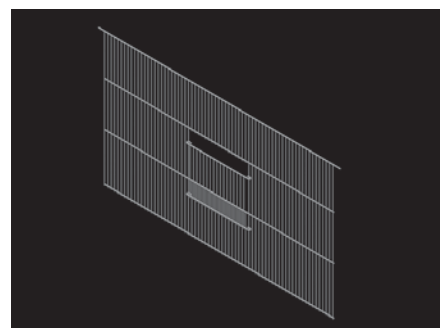
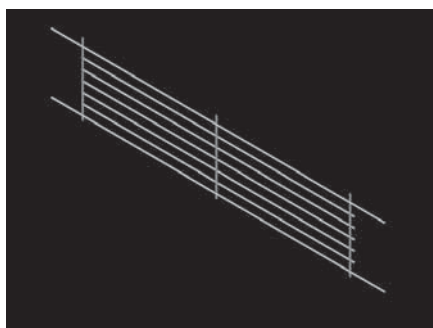
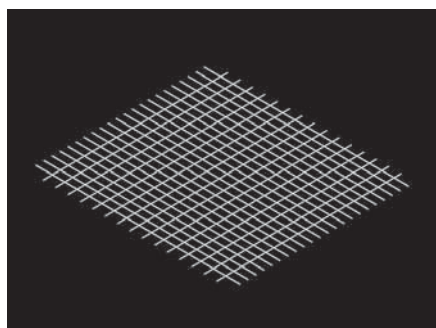
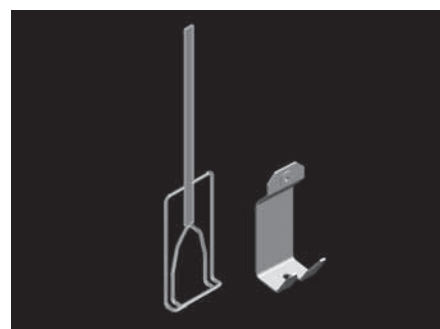
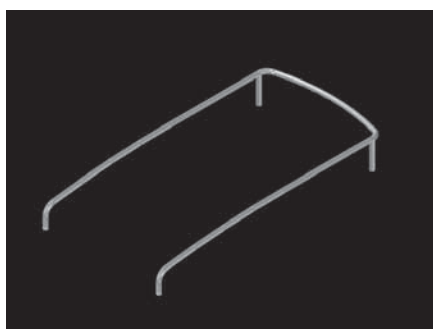
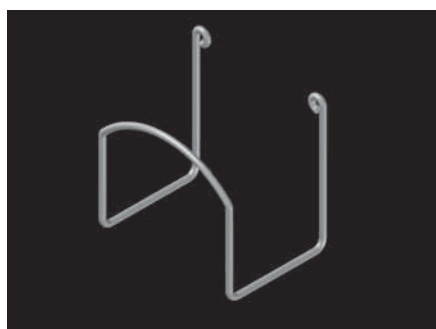
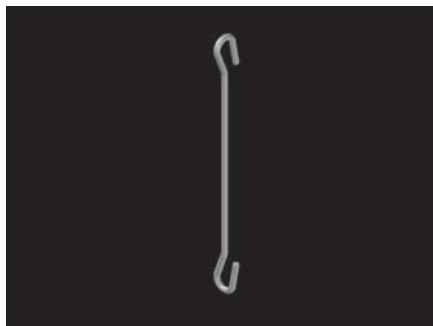
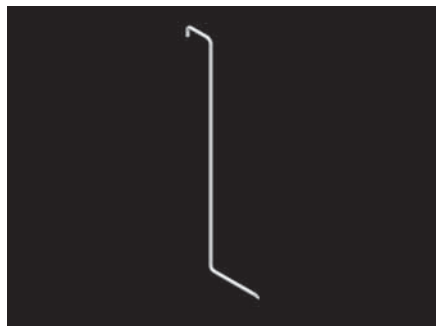

More products examples...  
Autres exemples de réalisations...  
Weitere Produktbeispiele...

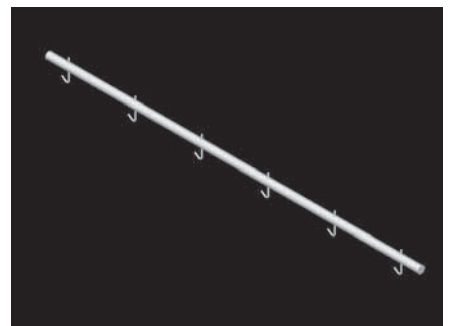
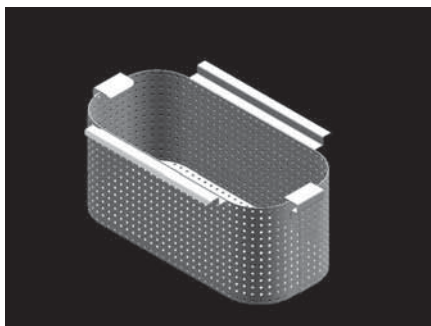
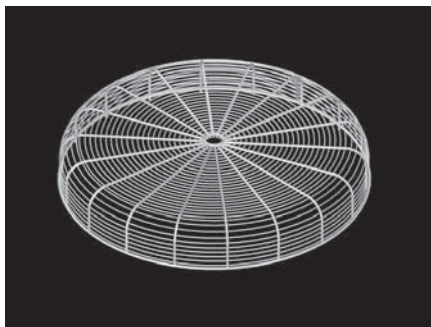
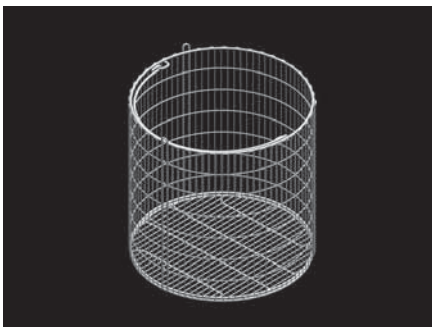
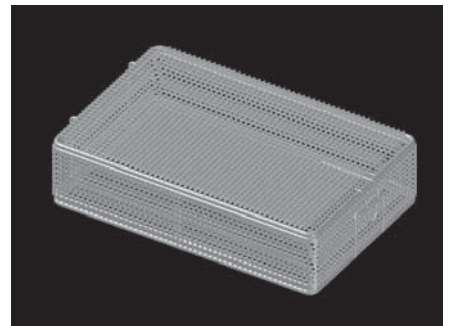
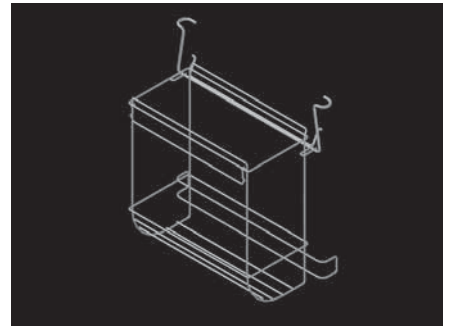
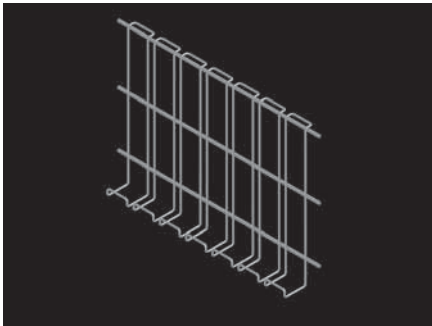
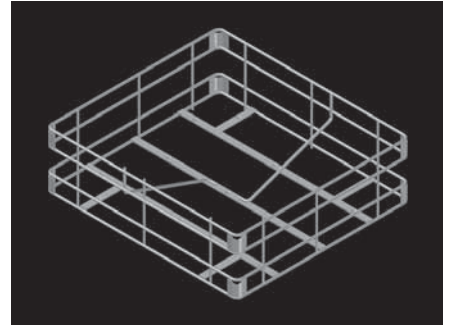
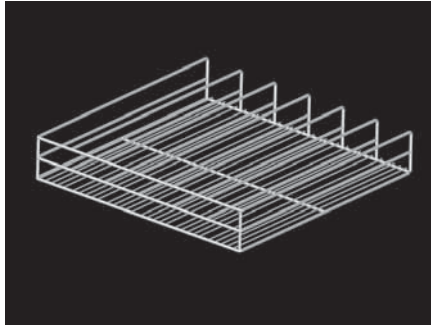
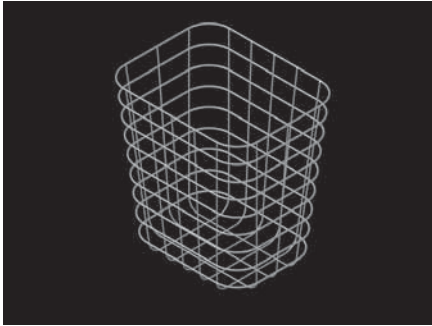

*filinox*



*filinox*

FILINOX-FLEXINOX, S.A.  
C/ Sant Adrià, 76 - E-08030 Barcelona (Spain)  
Tel. +34 932 232 662- Export. +34 932 988 795 - Fax +34 932 232 667  
e-mail: [filinox@inoxidables.com](mailto:filinox@inoxidables.com)

[www.filinox.es](http://www.filinox.es)

EMPRESA CERTIFICADA POR

